

	EQUIPAGGIAMENTI TECNICI LAVAGGIO	TESTINA AUTOMOVENTE A42-R2 SELF ROTATING CLEANING HEAD 25.52XX.XX		<div style="border: 2px solid black; padding: 2px;">4</div> 18
				

SPECIFICHE TECNICHE SPECIFICATIONS

- PRESSIONE NOMINALE <i>RATED PRESSURE</i>	40÷140 bar – 4÷14 MPa (580÷2000 psi)
- PRESSIONE CONSENTITA <i>PERMISSIBLE PRESSURE</i>	160 bar – 16 MPa (2300 psi)
- PORTATA <i>FLOW RATE</i>	15÷50 l/min (4÷13.2 GPM)
- TEMPERATURA MASSIMA ACQUA <i>MAX WORKING TEMPERATURE</i>	0–90°C (32–195°F)
- PESO <i>WEIGHT</i>	3.27 Kg (115.3 oz)
- FREQUENZA ROTAZIONE ASSE PRINCIPALE <i>MAIN AXIS ROTATING SPEED</i>	110÷180 giri/min (RPM)
- TEMPO CICLO BREVE <i>SHORT CYCLE TIME</i>	13÷8 secondi
- TEMPO CICLO COMPLETO <i>FULL CYCLE TIME</i>	25.5÷15.5 secondi
- ATTACCO ALIMENTAZIONE ACQUA <i>INLET CONNECTION SIZE</i>	1/2 Gas
- ATTACCO UGELLI N°3 (UGELLI NON FORNITI) <i>N°3 NOZZLE CONNECTIONS (NOZZLES NOT SUPPLIED)</i>	1/8 NPT

TESTINA AUTOMOVENTE

- Portata ridotta, alta pressione, elevata forza d'impatto.
- Velocità di rotazione indipendente dalla temperatura dell'acqua.
- Costruzione in acciaio inox e alluminio anticorrosivo anodizzato.
- Guarnizioni in viton e PTFE.
- Idonea per l'impiego nel settore alimentare.

SELF ROTATING CLEANING HEAD

- Reduced flow, high pressure, strong cleaning impact.
- Rotating speed independent from water temperature.
- Structure in SST and anodised anticorrosive aluminium.
- Seals in viton and PTFE.
- Designed for the food industry.

MISURE D'INGOMBRO OVERALL DIMENSIONS

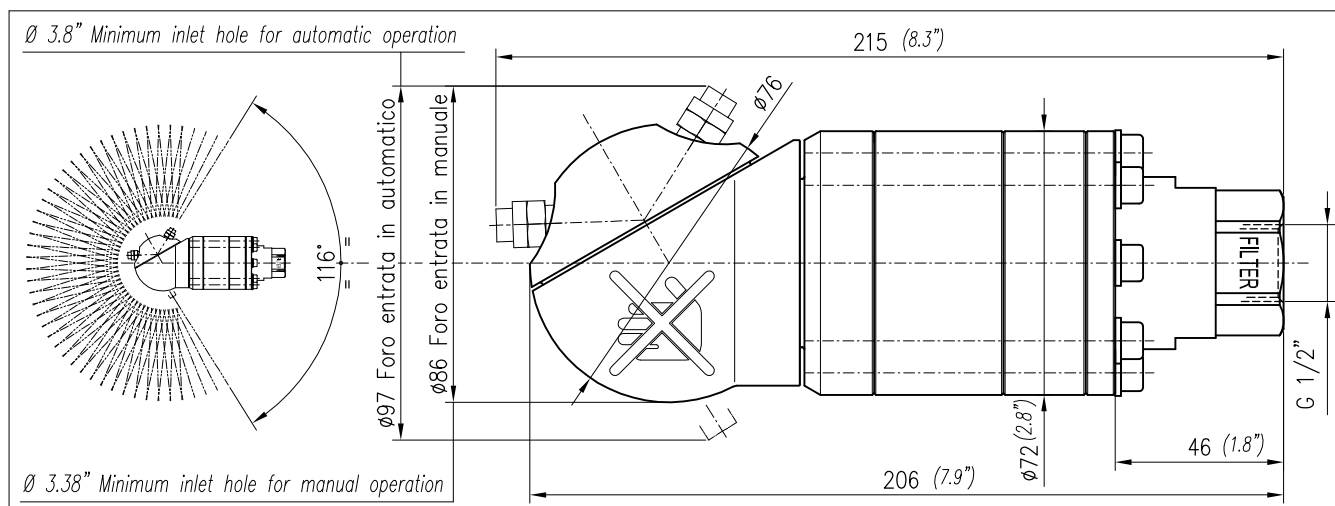

CARATTERISTICHE TECNICHE TECHNICAL SPECIFICATIONS

A42-R2



21/12/09

- PRESSIONE NOMINALE <i>RATED PRESSURE</i>	40÷140 bar - 4 ÷14 MPa (580÷2000 psi)
- PRESSIONE CONSENTITA <i>PERMISSIBLE PRESSURE</i>	160 bar - 16 MPa (2300 psi)
- PORTATA <i>FLOW RATE</i>	15÷50 l/min (4÷13.2 USGp.m.)
- TEMPERATURA MASSIMA ACQUA <i>MAX WORKING TEMPERATURE</i>	0-90°C (32-195°F)
- PESO <i>WEIGHT</i>	3.27 Kg (115.3 oz)
- FREQUENZA ROTAZIONE ASSE PRINCIPALE <i>MAIN AXIS ROTATING SPEED</i>	110÷180 giri/min (RPM)
- ATTACCO ALIMENTAZIONE ACQUA <i>INLET CONNECTION SIZE</i>	1/2 Gas
- ATTACCO UGELLI N°3 <i>NOZZLES CONNECTION N°3</i>	1/8 NPT

TEMPO PER UN CICLO COMPLETO DI LAVAGGIO
(47 GIRI DELL'ASSE PRINCIPALE)

TIME FOR A COMPLETE CLEANING CYCLE
(47 MAIN AXIS REVOLUTIONS)

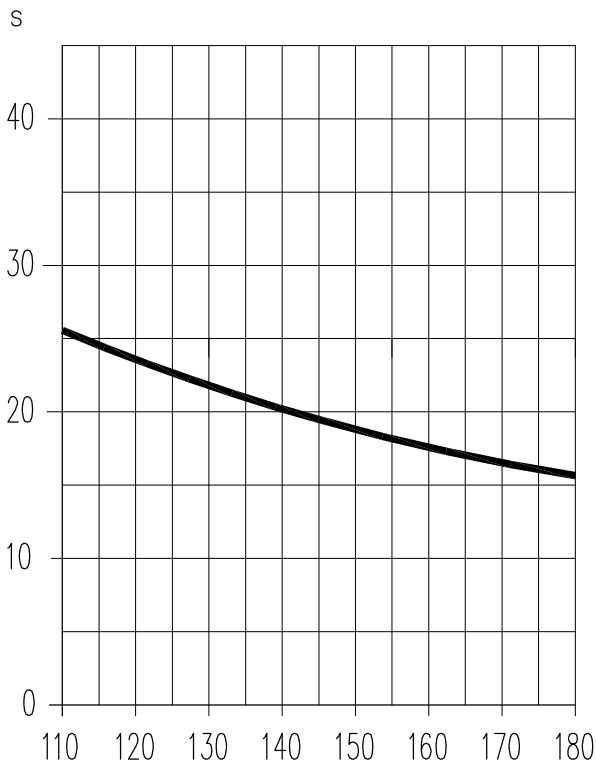

VELOCITA' DI ROTAZIONE giri/min
ROTATING SPEED RPM

TEMPO PER UN CICLO BREVE DI LAVAGGIO
(23,5 GIRI DELL'ASSE PRINCIPALE)

TIME FOR A SHORT CLEANING CYCLE
(23,5 MAIN AXIS REVOLUTIONS)

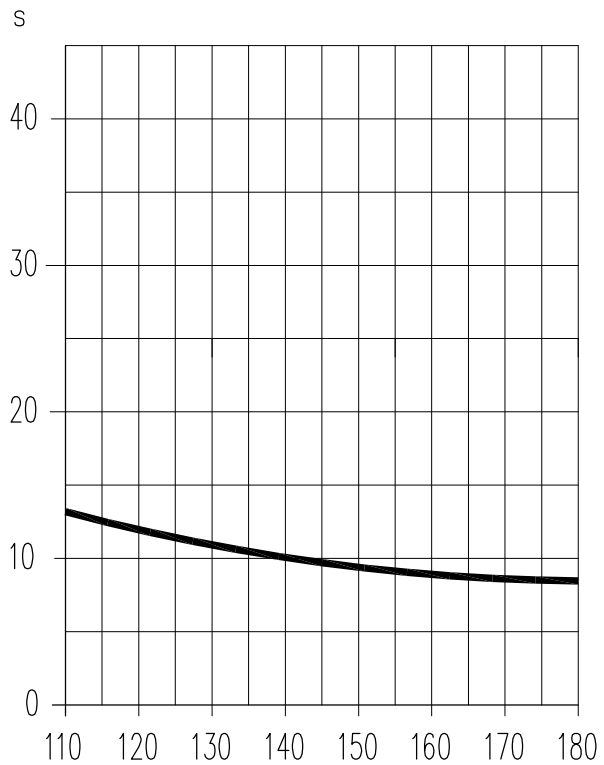

VELOCITA' DI ROTAZIONE giri/min
ROTATING SPEED RPM

-D1-



P.A. – S.p.A. – EQUIPAGGIAMENTI TECNICI DEL LAVAGGIO

VIA MILANO, 13 – CASELLA POSTALE 115 – 42048 RUBIERA (REGGIO EMILIA) – ITALY
 Tel. +39 0522 623611 – Fax. +39 0522 629600 – R.E.A. RE 156319 – R.I. RE11535 – Mecc. RE 013446
 C.F. e P. IVA 01035950359 – Cap. Soc. i.v. € 750.000,00 – Codice Identificativo C.E.E. IT 01035950359
 ART. 2497 – BIS C.C. DIREZIONE E COORDINAMENTO BENETTI srl R.I. TRIB. DI RE 01480690351
 Web: <http://www.pa-etl.it> – E-mail: info@pa-etl.it



Dichiarazione di conformità
Declaration of conformity

Attrezzatura – Equipment:		ACCESSORIO A PRESSIONE PRESSURE EQUIPMENT	
Modello – Type:		A42R / A42R2	
Fluido – Fluid:		ACQUA CALDA E DETERGENTI HOT WATER AND DETERGENTS	
Gruppo fluidi: <i>Group of Fluid:</i>	II	Temperatura min. e max. ammissibile <i>Permissible Temperature (min/max °C)</i>	0 ÷ 90°C

Procedura di valutazione della conformità
Conformity Assessment Procedure Followed

Allegato: <i>Annex:</i>	-----	Modulo: <i>Module:</i>	-----
Organismo notificato - Notified Body:		-----	
Attestato CE del tipo - EC Type - Examination Certificate:		-----	
Marcatura CE del fabbricante - Manufacturer's CE Marking:		-----	
Organismo Notificato per il Sistema Qualità: <i>Notified Body for Assessment of Quality System:</i>		-----	
Organismo di certificazione per il Sistema di Qualità: <i>Notified Body for Certification of Quality System:</i>		DNV-GL	
Norme europee applicate: <i>Harmonized Standards applied :</i>		CEI EN 60335-2-79:2015 UNI EN 1829-1:2010	
Codici di calcolo: <i>Design Calculations Applied:</i>			

Libretto uso e manutenzione presente nel sito web <i>Operation and Maintenance Manual</i> <i>available on Website</i>	Il Fabbricante PA SpA <i>The Manufacturer PA SpA</i>	
--	--	--

25.5200.20 A42 R2 Test.angolare 2 stadi, 20 l/min

25.5200.24 A42 R2 Test.semov., 25 l/min

25.5200.28 A42 R2 Test.semov., 30 l/min

25.5200.33 A42 R2 Test.semov., 50 l/min

25.5200.34 A42 R2 Test.semov., 40 l/min

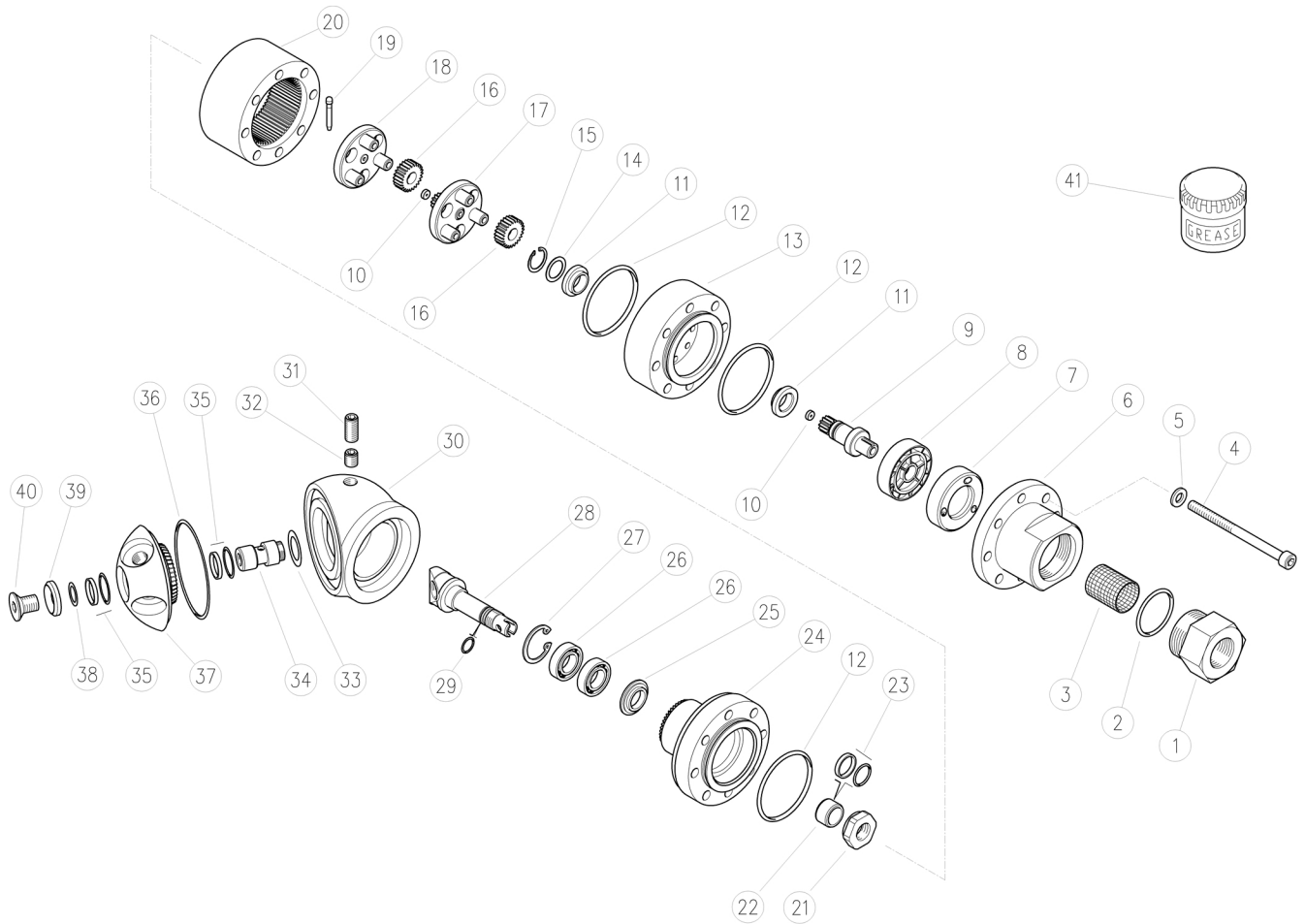

Pos.	Codice	Descrizione	Q.tà	K1	K2	K3	K4
1	80.0534.51R	Racc. entrata G1/2F inox	1				3
2	10.3077.10R	An.OR 1,78x28,3 mm Vi 70	1	•			10
3	80.0820.63R	Rete, 21,5x26,5 mm Ai316 inox	1				10
4	16.1908.00R	Vite DIN912 M6x80 mm inox	8				10
5	14.3569.05R	Rosetta 6,4x11x1mm inox	8				10
6	80.0533.51R	Corpo entrata inox	1				1
7	80.0514.51R	An. Iniettore 3x2 mm inox (1)	1				3
7	80.0519.51R	An. Iniettore 3x2,4 mm inox (2)	1				1
7	80.0515.51R	An. Iniettore 3x2,6 mm inox (3)	1				3
7	80.0525.51R	An. Iniettore 5x3,3 mm inox (4)	1				1
7	80.0526.51R	An. Iniettore 4x3,2 mm inox (5)	1				3
8	80.0512.84R	Turbina plast.	1				3
9	80.0540.22R	Albero planetario completo	1				1
10	80.0536.38R	An. Rasamento 1,2x6x2mm bronzo **	2	•			3
11	80.0548.84R	Boccola	2	•			3
12	10.3034.10R	An.Or 1,5x45 mm Vi 70	3	•			10
13	80.0532.51R	Flangia entrata acc.inox	1				1
14	80.0510.53R	An. rasamento 12,3x17x0,5mm inox	1				10
15	10.0999.05R	An. elast. E 12 inox	1	•			10
16	80.0501.38R	Satellite z.24 bronzo	6	•			3
17	80.0541.22R	Portasatelliti+3 perni+ingran. Z.12 inox	1				1
18	80.0538.22R	Portasatelliti+3 perni inox+ spina	1				1
19	80.0545.31R	Spina fusibile D.3mm **	1	•			10

** Su richiesta

Kit	Codice	Descrizione	Q.tà
K1	25.5181.24	Kit ric.guarn. A42R 6x1pz.	1
K2	25.5182.24	Kit ric. A42/43/44 7x1pz.	1
K3	25.5183.24	A42/43/44 - kit ric.bocc+guarn.2x1	1

Pos.	Codice	Descrizione	Q.tà	K1	K2	K3	K4
20	80.0524.51R	Corona z.60 per testina 2 stadi inox	1				1
21	80.0504.51R	Ghiera M12x1 inox	1				3
22	80.0509.51R	Boccola porta guarnizioni inox	1		•		3
23	10.2035.16R	Guarn.16x21x2,1 mm +Or Vit.	1	•		•	5
24	80.0552.51R	Ingranag.fisso z:45 inox.	1				1
25	80.0550.51R	Distanziale, 12,3x27,5mm inox	1				5
26	11.4412.28R	Cuscinetto 12x28x8 mm - 2RS1 inox	2	•			3
27	10.1011.05R	An. elast. I 28 inox	1	•			10
28	80.0551.51R	Albero di trasmissione inox.	1				1
29	10.3019.10R	An.OR 1,5x9,5 mm Vi 70	1	•			10
30	80.0523.41R	Calotta sferica A42R/R2 Al.	1				1
31	16.2225.00R	Grano DIN913 M8x16 mm inox	1				10
32	16.2218.00R	Grano M8x8 mm inox Uni 5929	1				10
33	80.0513.53R	An. rasamento 15,4x23x0,3mm inox	1				5
34	80.0507.51R	Perno M12x1M-M8 F inox	1				3
35	10.2035.00R	Guarn. stelo 15x20x2 mm +OR	2	•			4
36	10.3270.10R	An.OR 3,53x59,92 mm Vi 70	1	•			10
37	80.0539.22R	Portaug.3x1/8Npt Al+ingr.z.47	1				1
38	80.0505.53R	An. rasamento 8,3x14x0,3mm inox	1				5
39	80.0015.51R	Rosetta svas. 8,5x22x4,5mm inox	1				3
40	16.1954.12R	Vite DIN7991 M8x12 mm inox	1				10
41	14.6550.00R	Grasso al teflon x30 g.>no Epdm **	1				2
42	80.0506.51	Albero di trasmissione inox	1				1

(1) 25.5200.20 (2) 25.5200.24 (3) 25.5200.28 (4) 25.5200.33 (5) 25.5200.34

25.5200.20 A42-R2 Tank clean.,2-stage, 20 l/min
 25.5200.24 A42-R2 Tank clean.,s/prop., 25 l/min
 25.5200.28 A42-R2 Tank clean.,s/prop., 30 l/min

25.5200.33 A42-R2 Tank clean.,s/prop., 50 l/min
 25.5200.34 A42-R2 Tank clean.,s/prop., 40 l/min

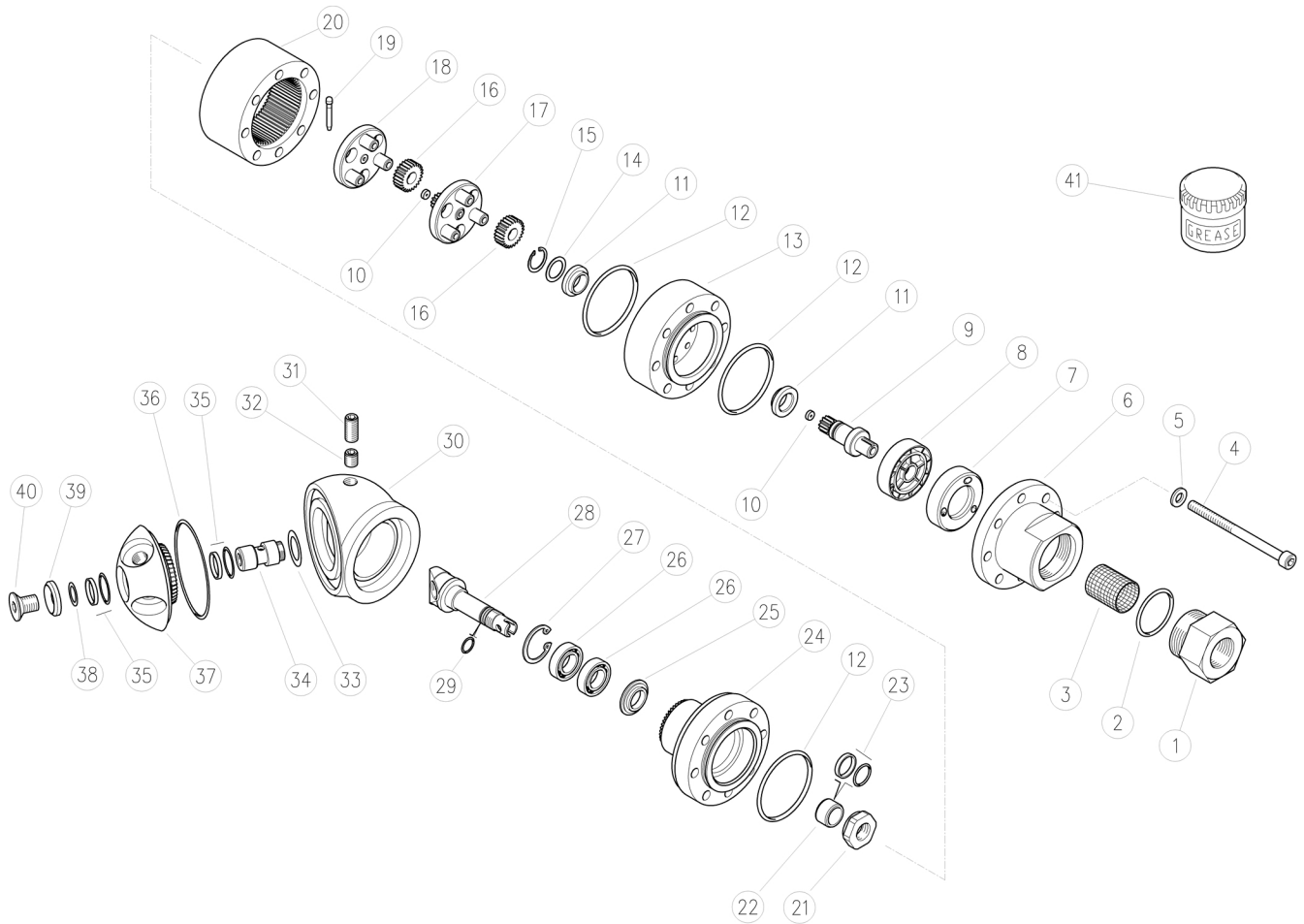

Pos.	P/N	Description	Q.ty	K1	K2	K3	K4
1	80.0534.51R	Inlet coupl., 1/2Bsp F Sst.	1				3
2	10.3077.10R	O-ring, 1,78x28,3 mm Vi 70	1	•			10
3	80.0820.63R	Net, 21,5x26,5 mm Ai316 Sst.	1				10
4	16.1908.00R	Screw, DIN912 M6x80 mm Sst.	8				10
5	14.3569.05R	Washer, 6,4x11x1 mm Sst.	8				10
6	80.0533.51R	Inlet housing, Sst.	1				1
7	80.0514.51R	Ring injector, 3x2 mm Sst. (1)	1				3
7	80.0519.51R	Ring injector, 3x2,4 mm Sst. (2)	1				1
7	80.0515.51R	Ring injector, 3x2,6 mm Sst. (3)	1				3
7	80.0525.51R	Ring injector, 5x3,3 mm Sst. (4)	1				1
7	80.0526.51R	Ring injector, 4x3,2 mm Sst. (5)	1				3
8	80.0512.84R	Turbine, plast.	1				3
9	80.0540.22R	Planetary shaft, complete	1				1
10	80.0536.38R	Shim ring, 1,2x6x2mm brz **	2	•			3
11	80.0548.84R	Bushing ring	2	•			3
12	10.3034.10R	O-ring, 1,5x45 mm Vi 70	3	•			10
13	80.0532.51R	Sst. inlet flange	1				1
14	80.0510.53R	Shim ring, 12,3x17x0,5mm Sst.	1				10
15	10.0999.05R	Snap ring, E 12 Sst.	1	•			10
16	80.0501.38R	Planetary gear, z.24 brz	6	•			3
17	80.0541.22R	Plan. gear holder+3 pins+gear, Sst.	1				1
18	80.0538.22R	Planetary gear holder+3 pins, Sst.+1 pin	1				1
19	80.0545.31R	Fuse plug, D.3mm **	1	•			10

Pos.	P/N	Description	Q.ty	K1	K2	K3	K4
20	80.0524.51R	Ring gear z.60, 2-stage cleaner, sst.	1				1
21	80.0504.51R	Ring nut, M12x1 Sst.	1				3
22	80.0509.51R	Seal holding bushing, Sst.	1		•		3
23	10.2035.16R	Seal, 16x21x2,1 mm+Or.iVit.	1	•	•		5
24	80.0552.51R	Pinion z:45 sst.	1				1
25	80.0550.51R	Sst. spacer ring, 12,3x27,5 mm	1				5
26	11.4412.28R	Ball-bearing, 12x28x8 mm - 2RS1 Sst.	2	•			3
27	10.1011.05R	Snap ring, I 28 Sst.	1	•			10
28	80.0551.51R	Propeller shaft, Sst.	1				1
29	10.3019.10R	O-ring, 1,5x9,5 mm Vi 70	1	•			10
30	80.0523.41R	Spherical cap -A42R/R2, Al.	1				1
31	16.2225.00R	Set screw, DIN913 M8x16 mm Sst.	1				10
32	16.2218.00R	Set screw, M8x8 mm Sst. Uni 5929	1				10
33	80.0513.53R	Shim ring, 15,4x23x0,3mm Sst.	1				5
34	80.0507.51R	Pin, M12x1M-M8F Sst.	1				3
35	10.2035.00R	Stem seal, 15x20x2 mm +O-ring	2	•			4
36	10.3270.10R	O-ring, 3,53x59,92 mm Vi 70	1	•			10
37	80.0539.22R	Nzl hold,3x1/8Npt Al+gear z.47	1				1
38	80.0505.53R	Shim ring, 8,3x14x0,3mm Sst.	1				5
39	80.0015.51R	C/sunk washer, 8,5x22x4,5mm Sst.	1				3
40	16.1954.12R	Screw, DIN7991 M8x12 mm Sst.	1				10
41	14.6550.00R	Teflon grease x30g.>no Epdm **	1				2
42	80.0506.51	Propeller shaft, Sst.	1				1

** On request

Kit	P/N	Description	Q.ty
K1	25.5181.24	Seals Spares Kit - A42R 6x1pcs.	1
K2	25.5182.24	Spares Kit - A42/43/44 7x1pcs.	1
K3	25.5183.24	Spares Kit - A42/43/44 2x1pcs.	1

(1) 25.5200.20 (2) 25.5200.24 (3) 25.5200.28 (4) 25.5200.33 (5) 25.5200.34